



## GIS for power distribution network: A case study of Karachi, Pakistan

Syed Nawaz-ul-Huda<sup>1</sup>, Farkhunda Burke<sup>2</sup>, Muhammad Azam<sup>3</sup>, Shazia Naz<sup>3</sup>

<sup>1</sup>DAWN-GIS, Dawn Media Groups, Zia-uddin Ahmed Road, Karachi, Pakistan, <sup>2</sup>Department of Geography, University of Karachi, Karachi, Pakistan, <sup>3</sup>Department of Geography Federal Urdu University of Arts, Science and Technology, Karachi Campus, Karachi, Pakistan.

Correspondence: Syed Nawaz-ul-Huda (email: nawaz\_huda@hotmail.com)

### Abstract

Due to rapid population increase and accelerated daily energy demand, electricity theft has become one of the common crimes in developing countries. Load shedding is observed not only for electricity but also for natural gas leading to further revenue losses for the state. The energy sector in Pakistan has long been facing serious problems of electricity generation and distribution. The aim of this paper is to present a case for a GIS modeling for Spatial Electricity Management System in Karachi so as to help circumvent the recurrent problems of electricity theft and mal-distribution in the city.

**Keywords:** electricity distribution, electricity generation, electricity theft, GIS modeling, Spatial Electricity Management System, the *Kunda* system

### Introduction

Light is life, and electricity has become one of the essential needs of the modern world. It has brought with it innovations which have worked many wonders in our lives which now seem impossible without it. Electricity powers our lights, provide heating and energy for electronic appliances and a host of essential services which we now take for granted. However, electricity has much more important aspects because it is a fundamental feature of all matter. Electricity is the force that holds together the molecules and atoms of all substances. Economic development is very closely and directly linked with energy development (Burke, 2004). It is one of the basic infrastructure through which development in industrial, commercial, agricultural and residential sector, as also in transport can take place. The Karachi Electric Supply Company (KESC) and Pakistan Atomic Energy Commission are key electric power producers of Pakistan Water and Power Development Authority (WAPDA) while some Independent Power Producers (IPPs) are also contributing considerable production to the energy sector of Pakistan (Pervez, 2009).

The energy sector in Pakistan has long been facing serious problems of electricity generation and distribution (Ali & Badar, 2010; World Bank, 2006). Rapid population increase has accelerated the energy demand with the passage of each day (USAID, 2007). Due to losses entailed in the power sector government authorities, as well as the generation policy of the country is unable to satisfy all stakeholders (Edms, 2007). Energy crises are spiraling every minute and load shedding is being observed not the supply of only in electricity but also in natural gas provision. This situation has led to economic decay and has reduced the recovery of taxes (Ali & Badar, 2010). The escalating rates of the energy sector is a back breaking burden which is scaring away investors, thus creating a scarcity of job opportunities, leading to deterioration in the economic as well as social sphere (Yoo & Joo-SukLee, 2010; Yoo & Kwak, 2010; Yoo, 2006; Morimoto & Hope, 2004).

In the developing countries, huge losses both in technical and non-technical terms are very common in the power distribution system (Ibrahim, 2000; Shrestha & Bhattarai, 1994; Alam et al., 2004). Electricity theft is one of the most common crimes in developing countries and some of the

developed countries (Luisa et al., 2010; Auriol & Blanc, 2009; Smith, 2004; Priatna, 1999; Lovei & McKechnie, 2000 & Nesbit, 2000). In the case of Pakistan, it is observed that development of modern technology and technique does not take pride of place in government and semi government strategies. The time now is ripe to introduce modern development in all sectors of the economy, especially in the utility sector.

This paper proposes the implementation of GIS for power distribution and theft control in Karachi. The aim is to identify patterns of distribution, demand, consumption and losses, hence identify priority areas for investment. By assessing the power demand scenario, electricity can subsequently be supplied to targeted areas, accordingly. A cross-sectoral view of the energy demand patterns, using physical data and available country statistics, incorporated into a GIS master database has been made. Based on geo-referenced data of population and existing infrastructure, a spatial assessment of levels of energy requirement and socio-economic development is possible. Henceforth, based on local conditions and need assessments the development of a profitable energy distribution system may be possible. The points thus aggregated will provide an indicator of energy demand for electricity planning at district level. The accomplishment of this preliminary task will go a long way in the targeting of specific areas in designing optimised supply systems which include off-grid renewable energy plants.

## Study area

Karachi is the financial hub and backbone of Pakistan's economy, which handles all sorts of trade by sea, as well as by land and air (Saifullah et al., 2004). Karachi, because of its location, its investment in energy production, its developed port facilities and other infrastructure elements, along with the presence of a successful entrepreneurial class, witnessed a vigorous growth in the field of manufacturing and textiles, chemicals, pharmaceuticals and steel. In 1998, the population was recorded at 9.8 million, while the current projected population (i.e., 2011) is 16 million.

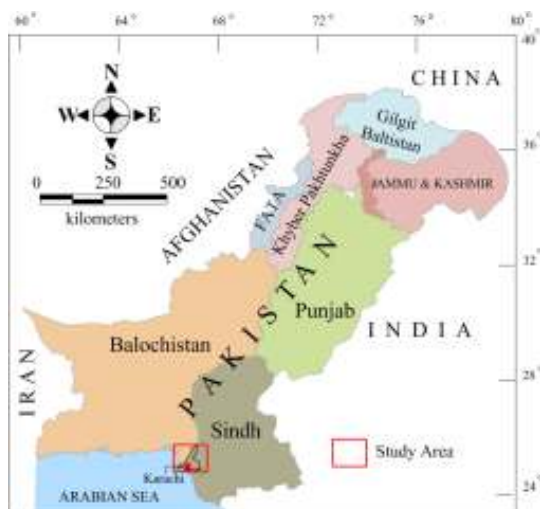
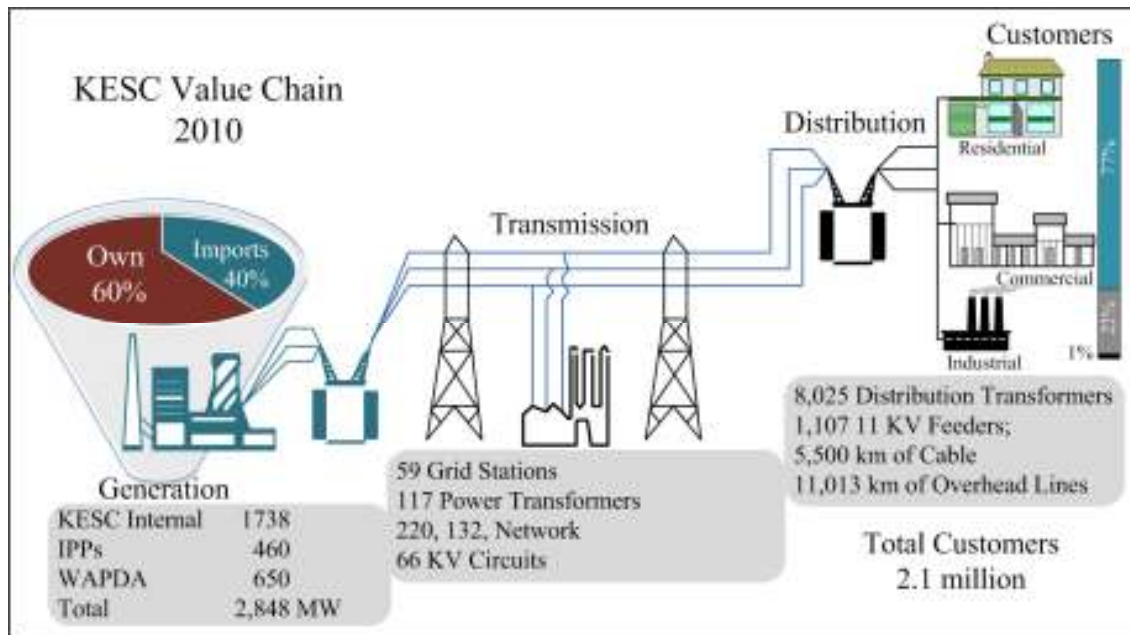

Figure 1. The study area

## Electricity theft problems in the study area

The Karachi Electric Supply Co. Ltd. (KESC) was established on 13 September 1913 under the Indian Companies Act, 1882 and henceforth has been responsible for the electricity generation and distribution, while, in 1952 the Government of Pakistan has taken over majority share and control. KESC is engaged in generation, transmission and distribution of electrical energy to the industrial, commercial, agricultural and residential consumers of the city of Karachi and its suburbs (Pervez,

2009). KESC is an integrated power utility body with exclusive franchise rights to serve Karachi and its surrounding areas, Gharo and Bela towns in district Thatta and Lasbela districts respectively spanning a licensed network area of 6,500 square kilometers; it thus facilitates approximately 18 million people (KESC, 2010).



Source: KESC, 2010

Figure 2. KESC value chain 2010

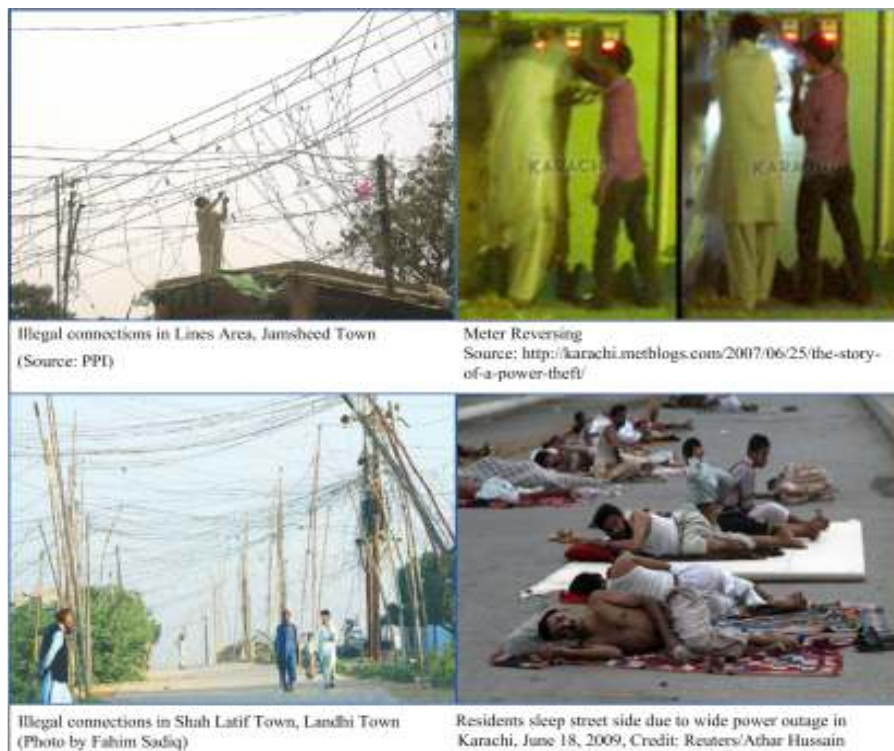

Figure 3. The Kunda System, meter tempering and effect of load shedding on residents

The KESC claims huge power losses hence heavy financial liabilities. Power thefts result in incessant load-shedding, crippling financial losses and disruption in the lives of the people of Karachi and its adjoining areas. Electricity theft is one of the common crimes in Pakistan but is not unique as developing countries in South Asia are highly susceptible to such theft, but the magnitude of the problem is abnormally large in Pakistan (Antmann, 2009). Like in all other sectors, with reference to energy and power provision and its manipulation it is the poor masses who have to face serious punishments for trivial misdeeds.

There are 4 methods of power theft i.e., (1) *Kunda* (2) meter reversing (3) underhand dealing and (4) power mafia. The *Kunda* system is the most popular method of power theft among the masses (Figure 3). It is most common in the congested areas, with narrow lanes approximately 40 feet wide, where the KESC poles were close enough to house galleries to enable suspension of hooks with the help of sticks or rubber gloves, without connecting the wire through the regular electric meter provided by the KESC. According to KESC, approximately, 40 percent of the electricity theft is conducted through this system. Meter reversing is one in which the electric technician reverses electric meter to give lower readings every month. Underhand dealing is that in which the lineman and associated staff are regularly paid under-hand amounts to get the factories connected with the main power stream illegally. Finally, the power mafia organizes power theft in a highly organized manner, with areas demarcated for each group where they have their monopoly with the connivance of the political parties who wield power in different areas.

### **Power sector reforms**

Electricity systems in developing countries vary significantly in size, structure, and resource mix that complicate comparison and transfer of experience (Jamash, 2006). Several researches have been carried out in power sector reforms in terms of political, economic and structural dynamics in developing countries which have achieved their objectives to varying degrees (Bacon & Besant-Jones, 2001; Millan et al., 2001; Fischer & Serra, 2000; APEC, 2000).

In Pakistan, power sector reform programmes were launched after announcing \$500 million IDA credit approval by the World Bank in 2002. WAPDA was restructured into independent companies for privatization, i.e. eight distribution companies (DISCOs), three power generation companies (GENCOs) and the National Transmission and Dispatch Company (NTDC). There were some resistance to the privatization of the KESC (Chaudhry, 2002) but due to financial losses and failure to provide quality service (GoP, 2005) the transfer to the private sector was effected in 2005.

Unfortunately, Karachi consists of multi linguistic population who live in groups or pockets. The politics of Karachi can be divided into sectarian, linguistic, leftist and different types of mafia. Therefore, reforms in energy sector have not proved as fruitful because implementing and sustaining the restructuring, competition and regulations are more complicated than initially anticipated (Jamash, 2006).

### **GIS modeling for Spatial Electricity Management System**

Organised electricity distribution system plays a vital role in proper maintenance of demand and supply. Various electricity distribution systems are functioning in the world (Shaw et al., 2010; Erdogdu, 2009; Pacudan & Guzman, 2002) and could be used by Pakistan as guidelines in developing a system adapted to its local conditions.

The current GIS technology has a multidimensional approach in addition to being amenable to controlled planning, zoning of specific areas, preparation of land use inventories, site suitability assessments, and socio-demographic analysis, it is being generally utilized for mapping purposes. The value of maps in understanding and communicating planning issues is universally recognised although the more-sophisticated analytical applications, which contribute to other aspects of the planning process, are less developed.

Sustainable development is literally fuelled by the energy sector. In Karachi, the electricity sector has witnessed dramatic turmoils in generation and distribution in recent years. Various applications

regarding detection of power distribution losses have been made in the past few years (Trifunovic et al., 2011; Martin & Gil, 2008; Su, et al, 2005) and further insight is needed to develop new approaches based on specific characteristics and problems of different areas. Therefore, in order to tackle the problem of Karachi, an insight into the peculiarities of the megapolis and its populace with their socio-economic and political tendencies is essential.

Since the scenario of Karachi's power theft has sensitive political implications, a plausible method of tackling the problem could be through the publicity of authentic data pertaining to energy loss through the mass media. GIS provides a convenient method for the development of distribution management system. The model suggested here (Fig. 4) is one of the simplest database systems of the GIS regarding organized electricity management system for the KESC.

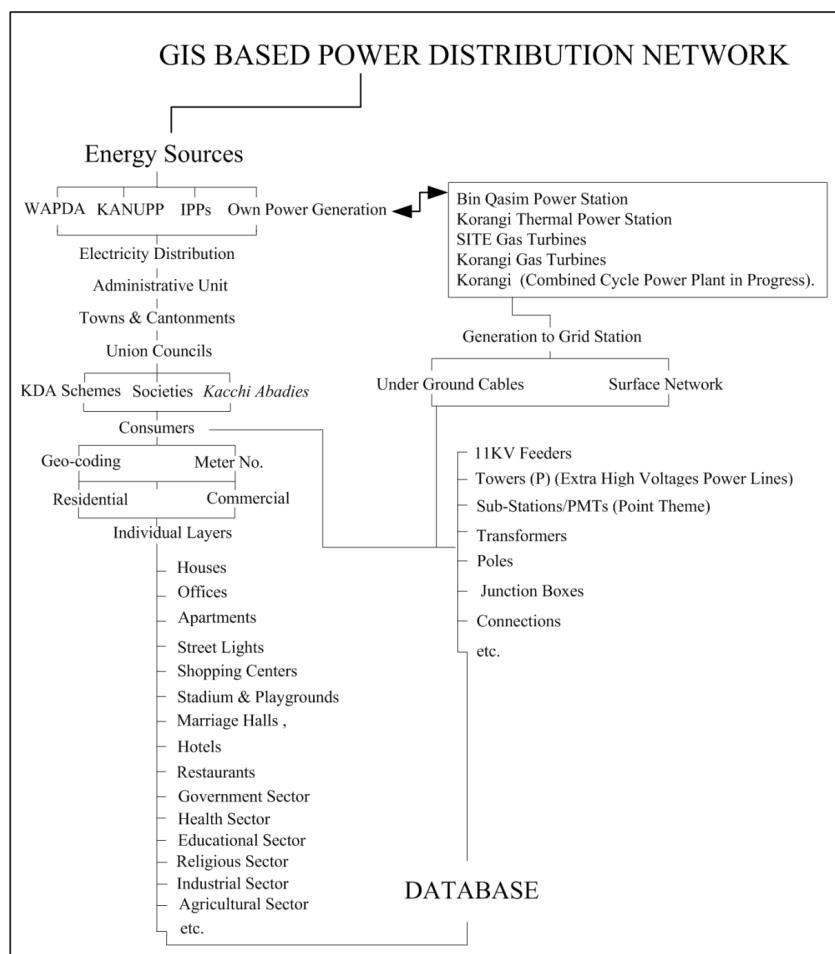

**Figure 4.** GIS based power distribution network

This model is based on the peculiar conditions of the study area. The KESC claims that electricity theft in the city is rampant (Fig. 5), but unfortunately names of various political groups topped the list, which resulted in a blame game debate regarding patronage/ownership of areas. The significance of this model is that it will enable the placing of all areas under surveillance with reference to electricity theft and line losses.

Subsequent to the development of the GIS database, the reasons of power outage will purely be the responsibility of the concerned authority. In addition, the administrative officials, the power sector, the political parties, the think tanks and the NGOs will be in a position not only to analyse future generation requirements but also to observe very clearly the distribution network and management. The GIS can also be utilised to provide significant spatial analyses for the evaluation of exclusive zones of high to low energy consumption in relation to income groups (Presta et al., 2007).

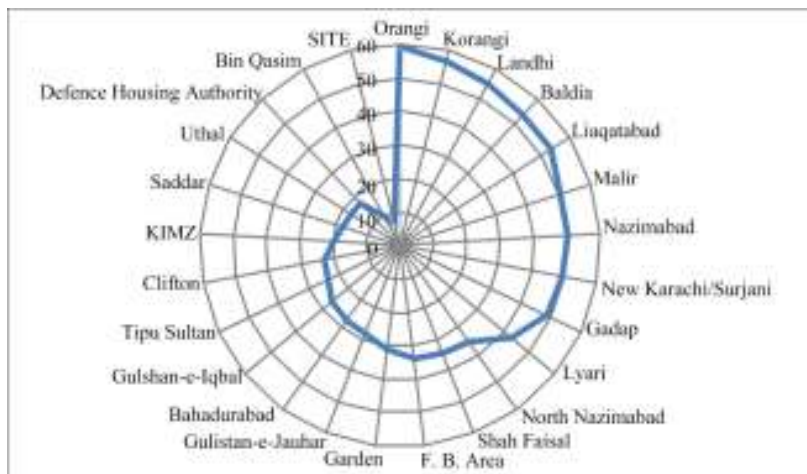

Source: KESC, 2010

**Figure 5.** Area wise average distribution losses (Jan 2010 - July 2010 )

In Figure 6, the implementation of the proposed model is shown as comprising a number of stages. Figures 6a & 6b depict most accurately the Town and Union Council limits, while 6c shows demarcation of Sheets (Schemes), Societies and *Kacchi Abadies*. Figure 6d shows data table in the suggested model. All this will pave the way for effective monitoring and improve the efficiency of the energy sector as well as for the possibility of lowering rates and enhancing quality of service (Jamasb, 2006).

## Conclusion

This GIS model has been designed to manage production and consumption of electricity in a transparent fashion whereby the company will publish consumption data on a monthly basis. If published on a house to house basis this consumption data will increase vigilance in the locality. In fact, it may provide a wide range of data for various types of analysis to enable foolproof management of power losses. It can be effectively utilised not only to manage information on the location and consumption particulars of individual consumers but also information regarding the distribution of electricity.

The selection of appropriate and cost-effective technology is the key to improving the distribution systems with their extensive conductors and installations. The selected technology should also be able to cater to future demand scenarios and to provide optimal solutions and not simply confined to analysing the present needs. The GIS technology allows for periodic updating and monitoring and the GIS mapping of the Electrical Network and Consumer Database helps in the way of improved load management, loss reduction, better revenue realisation, asset and work management and possibly better consumer relationships.



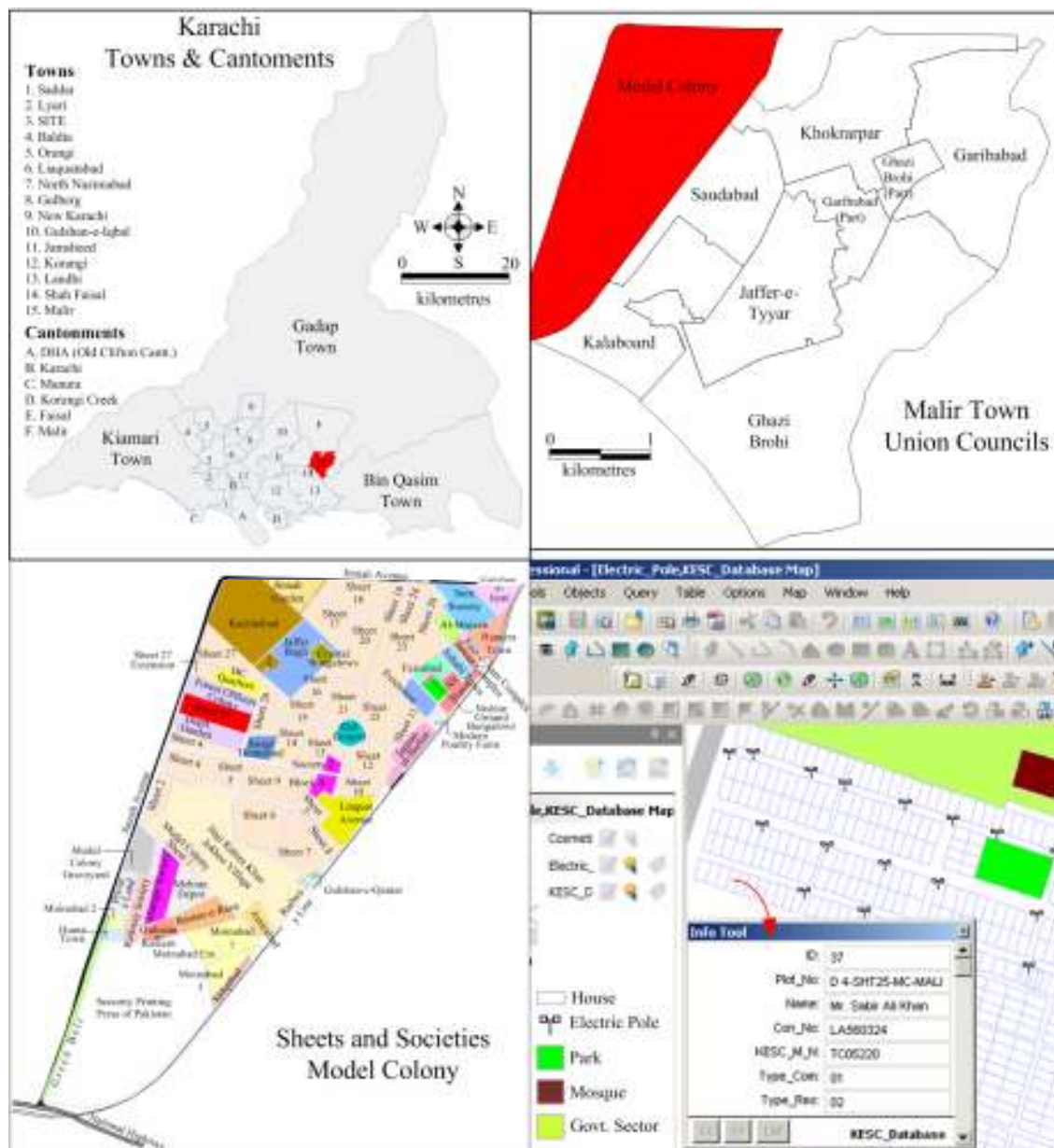

Figure 6. Stages of the database formation

## References

- Alam MS, Kabir E, Rahman MM, Chowdhury MAK (2004) Power sector reform in Bangladesh: Electricity distribution system. *Energy* 29, 1773–1783.
- Ali SS, Badar S (2010) Dynamics of circular debt in Pakistan and its resolution. *The Lahore Journal of Economics* 15, 61-74.
- Antmann P (2009) Reducing technical and non-technical losses in the power sector. Background Paper for the WBG Energy Strategy, Energy Unit World Bank, pp. 1-34.
- APEC (2000) Electricity sector deregulation in the APEC region. Asia Pacific Energy Research Center, Tokyo.
- Auriol E, Blanc A (2009) Capture and corruption in public utilities: The cases of water and electricity in Sub-Saharan Africa. *Utilities Policy* 17, 203–216.

- Bacon RW, Besant-Jones J (2001) Global electric power reform, privatization and liberalization of the electric power industry in developing countries. *Annual Review of Energy and the Environment* **26**, 331–359.
- Burke F (2004) Quality of life – Uttar Pradesh, India, Karachi. Madraswala Infotenment, Karachi, Pakistan.
- Chaudhry MB (2002) Performing Pakistan's power sector. *Gulf Pakistan Economist* July 15-21, 10-12.
- Edms (2007) Pakistan - Energy policies and actions, Ref. SA 07-003 Review of the International Energy Policies and Actions and the Latest Practice in their Environmental Evaluation and Strategic Environmental Assessment- Final Report: 1-7
- Erdogdu E (2009) Some thoughts on the Turkish electricity distribution industry. *Renewable and Sustainable Energy Reviews* **13**, 1485-1494
- Fischer R, Serra P (2000) Regulating the electricity sector in Latin America. *Ekonomia* Fall, 155–218.
- Government of Pakistan (GoP) (2005) KESC Privatization Handout, privatization commission of Pakistan, Islamabad November 29.
- Ibrahim ES (2000) Management of loss reduction projects for power distribution systems. *Electric Power Systems Research* **55**, 49-56.
- Jamasb T (2006) Between the state and market: Electricity sector reform in developing countries. *Utilities Policy* **14**, 14-30.
- KESC (2010) Karachi electric supply corporation. Business Report – 2010, pp. 1-41.
- Lovei L, McKechnie A (2000) The costs of corruption for the poor-the energy sector. Energy services for the world's poor. World Bank, Washington DC.
- Luisa M, Mimmi ML, Ecer S (2010) An econometric study of illegal electricity connections in the urban favelas of Belo Horizonte, Brazil. *Energy Policy* **38**, 5081–5097.
- Martin JA, Gil AJ (2008) A new heuristic approach for distribution systems loss reduction. *Electric Power Systems Research* **78**, 1953-1958.
- Millan J, Lora E, Micco A (2001) Sustainability of the Electricity Sector Reforms in Latin America, Research Department, Inter-American Development Bank. Prepared for the seminar Towards Competitiveness, The Institutional Path, March, Santiago.
- Nesbit B (2000) Thieves lurk-the sizeable problem of stolen electricity. *Electrical World T&D*, September/October.
- Pacudan R, Guzman E (2002) Impact of energy efficiency policy to productive efficiency of electricity distribution industry in the Philippines. *Energy Economics* **24**, 41-54.
- Pervez A (2009) Pakistan power sector, compiled report, OSEC. *Business Network Switzerland*, 1-18.
- Presta R, Daniella T, Ostendorf B (2007) Using GIS to evaluate the impact of exclusion zones on the connection cost of wave energy to the electricity grid. *Energy Policy* **35**, 4516–4528.
- Priatna DS (1999) Theft of electricity in Indonesia (PhD dissertation). University of Wisconsin, Madison.
- Saifullah MS, Ismail S, Khan HS, Saleem M (2004) Land use - Iron pollution in mangrove habitat of Karachi, Indus Delta. *Earth Interactions* **8**, 1-9.
- Shaw R, Attree M, Jackson T (2010) Developing electricity distribution networks and their regulation to support sustainable energy. *Energy Policy* **38**, 5927–5937.
- Shrestha RM, Bhattarai GB (1994) Utility planning implications of electricity loss reduction in developing countries: The case of Nepal. *Energy Policy* **22**, 531–537.
- Smith TB (2004) Electricity theft: A comparative analysis. *Energy Policy* **32**, 2067–2076.
- Su CT, Chang CF, Chiou JP (2005) Distribution network reconfiguration for loss reduction by ant colony search algorithm. *Electric Power Systems Research* **75**, 190–199.
- Trifunovic J, Mikulovic J, Djuriscic Z, Kostic M (2011) Reductions in electricity losses in the distribution power system in case of the mass use of compact fluorescent lamps. *Electric Power Systems Research* **81**, 465–477.
- USAID (2007) Energy Sector Assessment for USAID/Pakistan.
- World Bank (2006) Pakistan: Electricity Distribution and Transmission Improvement Project. Project Information Document.
- Morimoto R, Hope C (2004) The impact of electricity supply on economic growth in Sri Lanka. *Energy Economics* **26**, 77–85.



- Yoo S-H, Kwak So-Yoon (2010) Electricity consumption and economic growth in seven South American countries. *Energy Policy* **38**, 181–188.
- Yoo S-H, Suk Lee J (2010) Electricity consumption and economic growth: A cross-country analysis. *Energy Policy* **38**, 622–625.
- Yoo S-H (2006) The causal relationship between electricity consumption and economic growth in the ASEAN countries. *Energy Policy* **34**, 3573–3582.